

# FP40

Flow computer for calculating compensated flow and thermal energy of steam, water and other liquid media

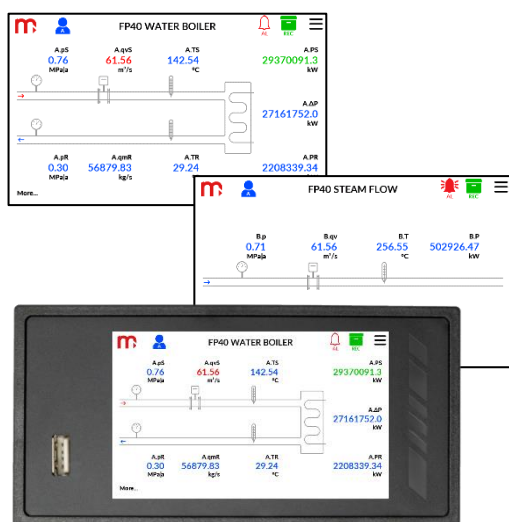

- Modular design of inputs and outputs
- Billing of 1 or 2 different measuring applications
- Auxiliary measurements and calculations
- Touchscreen 4" colour LCD display
- Graphical diagram of the measuring application
- Math channels, functions +, -, /, \*,  $\sqrt{\quad}$ ,  $\wedge$
- Alarm and control functions
- 4 output relays (6 more optional)
- 1 analog output 4-20mA (3 more optional)
- Port Ethernet, Modbus TCP Client/Server
- Port RS-485, Modbus RTU Master/Slave
- USB port on the front panel
- Email message on alarms status and totalisers
- Dedicated PC software for commissioning and archive data visualization
- Available languages: EN, DE, ES, FR, IT, PL, PT

FP40 is versatile and precise flow computer used for measurement of steam and water in various industrial installations, measurements of industrial gases and typical or special liquids (like glycol, supercooled water, oils) in heat exchange systems. There is possibility of local alarming or simple control implementation. Data are recorded and can be read locally or periodically using a USB mass storage device.

Device can communicate with master system via Ethernet port (Modbus TCP protocol, www server) or via RS-485 port (Modbus RTU protocol) and can work in distributed control systems.

Device may be configured by the user from the front panel or using commissioning software on PC.

## APPLICATIONS FOR STEAM, LIQUIDS AND TECHNICAL GASES

- For A, B main application setup one of possible applications using a configuration wizard:
  - the flow and heat of a liquid medium
  - the flow and delta heat of a liquid medium in a closed supply-return installation
  - the flow and delta heat of a liquid medium in an installation with different supply and return flow rates
  - the flow and heat of a steam
  - the flow and heat of steam for steam-condensate conditions
  - the flow and delta heat in a closed steam-condensate installation
  - the flow and delta heat in a steam-condensate installation with different steam and condensate flow rates
  - the flow and delta heat in a steam-generating installation with the supplied water flow rate measured
  - the flow and heat of a technical gases

## FLOW RATE MEASUREMENT

- The flow computer can work with:
  - mass flowmeters
  - volume flowmeters
  - differential pressure devices with approximation by square root curve or differential pressure devices (orifices and nozzles) according to iteration algorithm according to PN-EN ISO 5167 standard (only for water and steam)

## INPUTS AND CHANNEL TYPES

The FP40 can contain up to 12 analog inputs or HART and Modbus network modules. The FP40 in basic configuration has Ethernet port, RS-485 port, 4 alarm relays and one 4-20mA analog output and slots for two I/O modules from the table below. The computer has two measuring applications and up to 16 auxiliary channels that can be used as measuring or mathematical channels. The device enables power supply of the current loop for 0/4-20mA transducers. It is possible to define up to 10 user characteristics and up to eight additional user media, e.g. glycol, ammonia, heating oils.

Module code	Module type	Description
11	IN6I(24V)	six analog inputs with standard current loop output 0-20mA or 4-20mA powered from internal 24 VDC
12	IN6I	six analog inputs with standard current loop output 0-20mA or 4-20mA (or passive transmitters with external power supply)
23	IN6T	six analog inputs for connection temperature RTD sensors type Pt100, Pt200, Pt500, Pt1000, Ni100, Ni120, Ni1000, Cu50, Cu53, Cu100, KTY81, KTY83, KTY84 and connection thermocouples TC type J, L, K, U, E, N, B, R and S; and linear measurement of resistance 0 .. 4500 $\Omega$ or voltage -140 .. +140 mV
41	IN6V	six analog inputs for connecting as standard -10 .. +10 V, 0..10 V, 2 .. 10 V, 0 .. 5 V, 1 .. 5 V
53	IN6	six analog inputs, inputs 1-3 enable connection of RTD temperature sensors, TC thermocouples and linear measurement of resistance 0 .. 4000 $\Omega$ or -140 .. +140 mV, inputs 4-6 enable the connection of transducers in the 0 / 4-20mA standard, 0 / 2-10V, 0 / 1-5V
55	IN4SG	four analog inputs +/-30 mV for direct connection of strain gauges with a sensitivity of 1, 2, 4 mV / V or other, four discrete inputs for resetting (tare) analog inputs, power supply for strain gauges 5 VDC
61	IN6D	six binary inputs for status tracking, frequency measurement (0.1 .. 1000 Hz), pulse counting (0 .. 100 Hz) with the possibility of powering transducers
62	IN3D	three binary inputs for status tracking, frequency measurement (0.1 .. 12 500 Hz), pulse counting (0 .. 100 Hz) with the possibility of powering transducers
71	2RS485(24V)	two independent and galvanically separated RS-485 ports for reading transducers or other devices operating in the Modbus RTU standard; extra 24VDC voltage source power supply for external transducers
72	2RS485	two independent and galvanically separated RS-485 ports for reading transducers or other devices operating in the Modbus RTU standard
75	1HRT	one HART (4-20 mA) port with the possibility of powering transmitters, operating in the Primary Master mode or in the Secondary Master mode
81	OUT6RL	six solid state relays output rated at 24 VAC / 0.5 A or 36 VDC / 0.5 A
91	OUT3	three programmable analogue outputs 0/4-20mA, 0/1-5V, 0/2-10V
95	PSBATT	supplying the device with NiMH storage batteries in the event of voltage break (backup) or periodic operation with battery power supply (from 1 to 20 hours depending on the configuration)

## AVAILABLE OPTIONS AND ORDERING INFORMATION

FP40	Slot A	Slot B	
	-XX	-XX	Module code from the table above

Example:

- FP40 with HART module and 6 inputs 4-20mA has a code: **FP40-75-11**
  - **FP40 with 6 inputs 4-20mA has code: FP40-11-0**
- The sign 0 in the above code means that one module is installed in the device (on slot A).

## THE SCOPE OF MEASUREMENT OF STEAM, WATER PARAMETERS AND OTHER MEDIA

- The flow and heat measurement of superheated or saturated steam or water are according to IAPWS-IF97 recommendations in the operating range of temperature 0 .. 800 °C and absolute pressure 0.05 .. 16.52 MPa
- Flow and energy measurements of liquids other than water are performed in the range of tabular values entered by the user – density and enthalpy as function of temperature
- Measurement of technical gas flow according to the ideal gas equation

## TOTALIZERS

- Totalizers for energy and flow measurements (2 for each channel)
- Totalizers can be reset manually or automatically every day, week or month
- Over and under counters to be realized in additional channels X

## ALARMS AND CONTROL

- 2 alarm thresholds for each result
- Alarm or control mode, signaling failure of sensors connected to analogue inputs
- 4 solid state relays rated at 0.1 A/60 V
- E-mail messages about alarm states and cyclical reports with counter values (max. 5 recipients)

## RECORDING MEASUREMENT RESULTS

- Archive files:
  - process values (recording rate from 1 s up to 24 h)
  - totalizers values (record every 1 min up 24 h)
- Event files: authorization log file, event log file, settings log file (recording after the occurrence of the event)
- 2 recording rates, toggled by alarm state for shorting/opening time of selected binary inputs
- Access to recorded data through USB port on the front panel or through Ethernet port
- Checksum secured files – protection against data manipulation

## SCREEN EXAMPLES

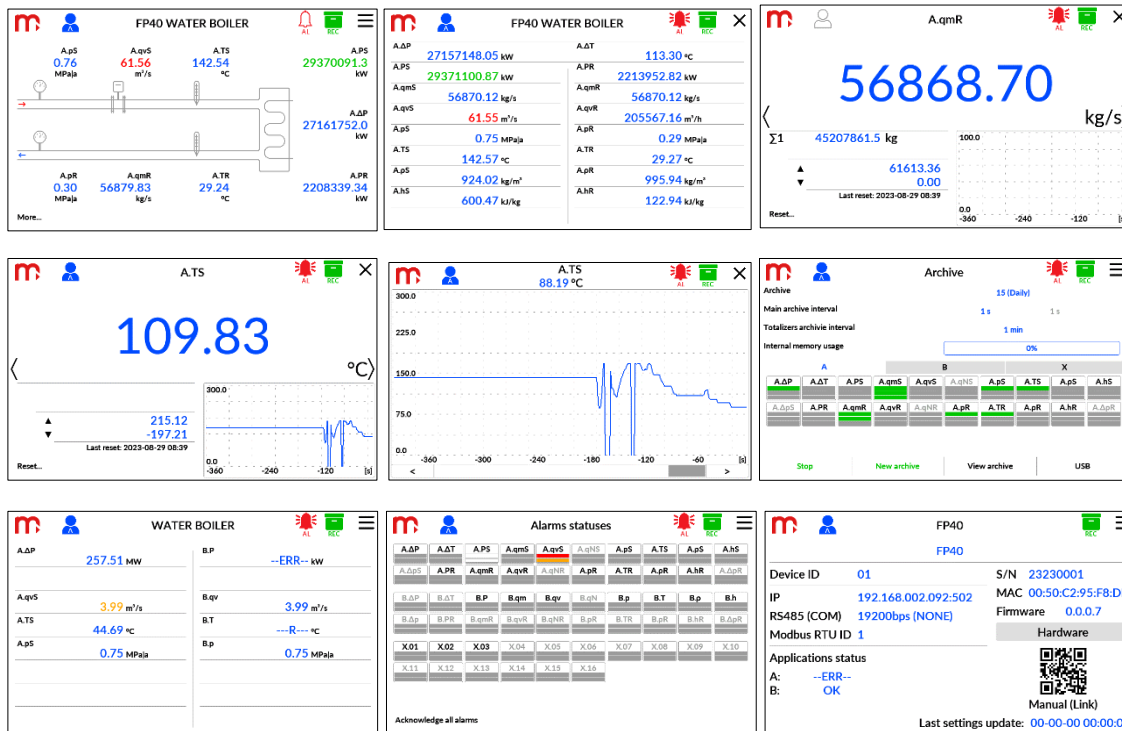

## SUPPLEMENTAL SOFTWARE

Supplemental software is available to configure the device (FP40 Config) and visualization of archival results (FP40-RPplus).

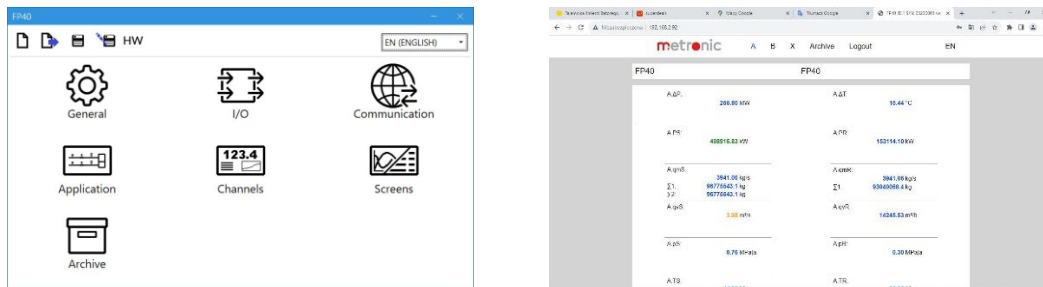

## APPLICATION EXAMPLE

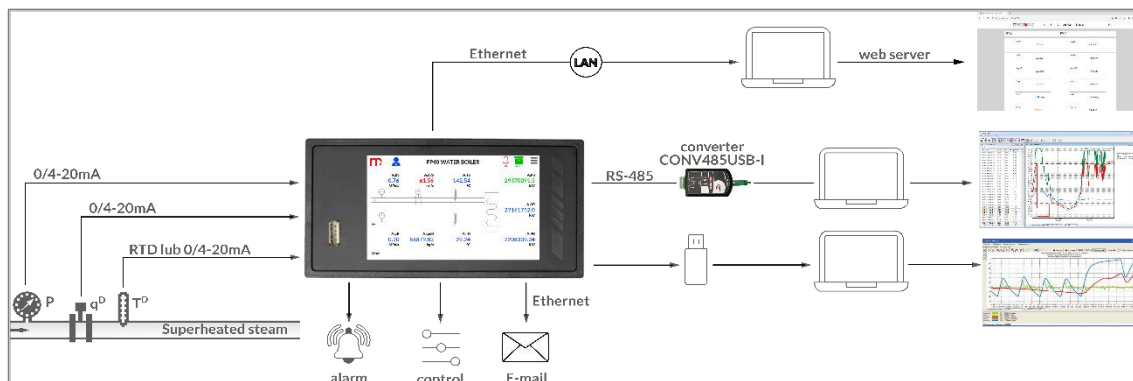

## TECHNICAL SPECIFICATIONS

Front panel	
Type of display	LCD TFT 4" 800 px X 480 px LED backlight
Display size	86.4 mm X 52.5 mm
Keyboard	resistive touch panel
Additional indication	LED RGB
USB Port - front panel	
Version	USB 2.0 (with limited functionality, for connection of FLASH storage)
Connector type	USB standard 'A' type socket
Ethernet Port - rear panel	
Interface	10/100 Base-T Ethernet
Connector type	RJ-45
Transmission protocol	Server WWW, Modbus TCP Client/Server ICMP (ping)
Modbus TCP Client	
Number of connections opened simultaneously	Max 20
Number of read values	Max 30
Modbus TCP Server	
Number of connections opened simultaneously	Max 4
RS-485 Serial Port - rear panel	
Signals output on terminal block	A(+), B(-)
Galvanic separation	None
Maximum load	32 receivers/transmitters
Transmission protocol	Modbus RTU Slave
Transmission rate	1.2, 2.4, 4.8, 9.6, 19.2, 38.4, 57.6, 115.2 kbps
Parity control	Even, Odd, None
Frame	1 start bit, 8 data bits, 1 stop bit
Maximum length of line	1200 m
Internal terminating resistor	V <sub>CC</sub> -A(+)-B(-)-G: 390 Ω - 220 Ω - 390 Ω (activated by DIP-switches)
Maximum differential voltage A(+), B(-)	-7 V .. +12 V
Minimum output signal of transmitter	1.5 V (at R <sub>L</sub> = 54 Ω)
Minimum sensitivity of receiver	200 mV / R <sub>IN</sub> = 12 kΩ
Minimum impedance of data transmission line	54 Ω
Short-circuit/thermal protection	Yes/Yes
Internal data memory	
Memory type	Flash
Capacity	2 GB
Estimated recording time for recording speed every 5 s for 16 measuring channels	ca. 2 years
Supply	
Supply voltage	24 VDC (20 .. 30 VDC)
Maximum power consumption	12 W
Security	The internal delay fuse 3.15 A, the exchange only by the service company

## Electrical connections (terminal connectors)

Type	screw terminal connectors
Wire cross section	solid and flexible: 0.14 .. 1.5 mm <sup>2</sup> flexible with bootlace ferrule 0.25 .. 1.5 mm <sup>2</sup> AWG 30 / 14

## Mechanical Dimensions - Housing

Type of housing	panel mount, nonflammable plastic material „Noryl”
Dimensions with connectors (w X h w X d)	144 mm X 72 mm X 127 mm
Dimensions of panel cut-out (w X h)	138 <sup>+1</sup> mm X 68 <sup>+0.7</sup> mm
Maximum panel thickness	5 mm
Weight	0.5 kg
Protection class	IP30 on front panel side IP20 on rear panel side

## Environmental conditions

Ambient temperature	0 .. +50 °C or 0 .. +40 °C depends on the device hardware configuration <sup>(1)</sup>
Relative humidity	5 .. 95% (without steam condensation)
Maximum altitude	< 2000 m above sea level
Storage temperature	-30 .. +70 °C
Degree of pollution	PD2
EMC	EMC Directive 2014/30/EU EN 61326-1:2013 Table 2 (immunity) EN 61326-1:2013 Class A (emission)
RoHS	RoHS Directive 2011/65/EU

<sup>(1)</sup>If module IN6I(24V) or 2RS485(24V) installed and operating as a power supply source for external devices, ambient temperature is limited to 0 .. +40 °C. In all other configurations the ambient temperature range is 0 .. +50 °C.

## Analog output 4-20mA

Output signal	4-20 mA (3.6 .. 22 mA)
Current loop supply	no (external supply required)
Maximum voltage between I+ and I-	28 VDC
Minimum supply current loop voltage	9 VDC (R <sub>L</sub> = 0 Ω)
Loop resistance (R <sub>L</sub> )	0 .. 500 Ω
Galvanic isolation to supply voltage	250 VAC; 1500 VAC for 1 minute

## Relay outputs

Number of outputs	4
Outputs type	Solid state relays
Maximum voltage	60 V AC/DC
Maximum load current	0.1 A

## I/O MODULES

## IN6I(24V); IN6I – 0-20mA or 4-20mA INPUT TYPE MODULE

Number of inputs	6
Measuring range	0–20 mA; 4–20 mA; (the actual range -22 .. 22 mA)
Resolution	0.001 mA
Measurement accuracy (T <sub>a</sub> = +25 °C)	< ±0.1% measuring range (typically < ±0.05%)
Temperature drift	< ±0.02% /°C measuring range
Input resistance	12 Ω ±10%

Maximum input voltage	± 40 VDC
Input protection	Polymer fuse 50 mA
Transducers powered from device:	
• module IN6I(24V)	24 VDC ±15% / max 22 mA
• module IN6I	None
Galvanic separation from the other circuits	250 VAC; 1500 VAC for 1 minute
Galvanic separation between channels	None

#### IN6T - SIX-CHANNEL TEMPERATURE INPUT MODULE

Number of inputs	6
Sensor type	<ul style="list-style-type: none"> <li>• Resistance (Table below); 0 .. 4500 Ω</li> <li>• Thermocouple (Table below); ±140 mV</li> </ul>
Measuring range	-140 .. +140 mV
Resolution	0.01 mV
Cold junction compensation	<ul style="list-style-type: none"> <li>• Any other temperature measuring channel (in °C/°F) or a constant value</li> <li>• Internal sensor measurement: accuracy ±2.5 °C (value can be calibrated by the user)</li> <li>• For thermocouple B - no compensation</li> </ul>
Maximum input voltage	± 40 VDC
Galvanic separation from the other circuits	250 VAC; 1500 VAC for 1 minute
Galvanic separation between channels	None

#### Specifications for input type RTD

Sensor connection type	2-wire; 3-wire; 4-wire
Sensor current	200 μA
Measuring range	0 .. 4500 Ω
Resolution	0.05 Ω
Wire resistance compensation in the 3-wire connection	Automatic
Wire resistance correction in the 2-wire, 3-wire, 4-wire connection	Constant within the range of -99.99 .. +99.99 Ω
Maximum resistance of the sensor wires	20 Ω

#### Specifications for input type TC

Measuring range	-140 .. +140 mV
Resolution	0.01 mV
Cold junction compensation	<ul style="list-style-type: none"> <li>• Any other temperature measuring channel (in °C/°F) or a constant value</li> <li>• Internal sensor measurement: accuracy ±2.5 °C (value can be calibrated by the user)</li> <li>• For thermocouple B - no compensation</li> </ul>

#### IN6V - VOLTAGE TYPE INPUT MODULE

Number of inputs	6
Sensor type	<ul style="list-style-type: none"> <li>• 0-10 V (2-10 V, 0-5 V, 1-5 V)</li> <li>• Linear voltage source</li> </ul>
Measuring range	-10 .. +10 VDC (or sub-range) (the actual range -11 .. +11 VDC)
Resolution	0.0001 V
Measuring range (T <sub>a</sub> = +25 °C)	< ±0.1% measuring range (typically < ±0.05%)
Temperature drift	< ±0.02% /°C measuring range
Input resistance	>100 kΩ
Maximum input voltage	± 40 VDC

Galvanic separation from the other circuits	250 VAC; 1500 VAC for 1 minute
Galvanic separation between channels	None

#### IN6 – SIX-CHANNEL UNIVERSAL MODULE OF ANALOG INPUTS

Number of inputs	6	1-3 inputs RTD, TC 4-6 inputs 4-20mA, 0-10VDC
Sensor type		<ul style="list-style-type: none"> <li>• Resistance (Table below); 0 .. 4500 <math>\Omega</math></li> <li>• Thermocouple (Table below); <math>\pm 140</math> mV</li> <li>• 0–20mA; 4–20mA (with loop supply module)</li> <li>• <math>\pm 10</math>V / 0-10V (2-10V, 0-5V, 1-5V)</li> </ul>
Maximum input voltage	$\pm 30$ VDC	
Galvanic separation from the other circuits	250 VAC; 1500 VAC for 1 minute	
Galvanic separation between channels	None	

#### Specifications for input type RTD

Sensor connection type	2-wire; 3-wire; 4-wire
Sensor current	200 $\mu$ A
Measuring range	0 .. 4500 $\Omega$
Resolution	0.05 $\Omega$
Wire resistance compensation in the 3-wire connection	Automatic
Wire resistance correction in the 2-wire, 3-wire, 4-wire connection	Constant within the range of -99.99 .. +99.99 $\Omega$
Maximum resistance of the sensor wires	20 $\Omega$

#### Specifications for input type TC

Measuring range	-140 .. +140 mV
Resolution	0.01 mV
Cold junction compensation	<ul style="list-style-type: none"> <li>• Any other temperature measuring channel (in <math>^{\circ}</math> C/<math>^{\circ}</math> F) or a constant value</li> <li>• Internal sensor measurement: accuracy <math>\pm 2.5</math> <math>^{\circ}</math> C (value can be calibrated by the user)</li> <li>• for thermocouple B – no compensation</li> </ul>

#### Specifications for input type 0-20mA, 4-20mA

Measuring range	0–20 mA; 4–20 mA; (acceptable range -22 .. 22 mA)
Resolution	0.001 mA
Measurement accuracy ( $T_a = +25$ $^{\circ}$ C)	< $\pm 0.1\%$ measuring range (typically < $\pm 0.05\%$ )
Temperature drift	< $\pm 0.02\%$ / $^{\circ}$ C measuring range
Input resistance	12 $\Omega$ $\pm 10\%$
Input protection	Polymer fuse 50 mA

#### Specifications for input type $\pm 10$ V / 0-10V

Measuring range	-10 .. +10 VDC (or sub-range) (acceptable range -11 .. +11 VDC)
Resolution	0.0001 V
Measuring range ( $T_a = +25$ $^{\circ}$ C)	< $\pm 0.1\%$ measuring range (typically < $\pm 0.05\%$ )
Temperature drift	< $\pm 0.02\%$ / $^{\circ}$ C measuring range
Input resistance	>100 k $\Omega$

#### IN4SG – FOUR-CHANNEL STRAIN GAUGE INPUT MODULE

Number of analog inputs	4
-------------------------	---



Number of binary inputs (tare)	4
Sensore type	Strain gauge sensor, strain gauge (quarter-, half-, full-bridge configuration available)
Measuring range	-30 .. +30 mV
Resolution	0,0001 mV
Accuracy	< ±0,1% of 10 mV range (typically < ±0,05%)
Temperature drift	< ±0,01% /°C of 10 mV range
Strain gauge bridge supply voltage	5 VDC
Minimum bridge resistance (4 inputs used)	250 Ω
Minimum bridge resistance (2 inputs used)	125 Ω
Minimum bridge resistance (1 inputs used)	62 Ω
Maximum input voltage	± 40 VDC
Galvanic separation from the other circuits	250 VAC; 1500 VAC for 1 minute
Galvanic separation between analog channels	None
Binary inputs (tare)	Voltage type activation; 24 VDC/5 mA ( range 10-36 VDC)
Switching level	ca. 6 VDC
Galvanic separation from the other circuits	250 VAC; 1500 VAC for 1 minute
Galvanic separation between binary channels	Yes (functional separation)

#### IN6D – BINARY INPUTS MODULE

Number of inputs	6
Sensor type	<ul style="list-style-type: none"> <li>• State tracking</li> <li>• Frequency measurement 0.1 .. 1000 Hz</li> <li>• Counting pulses (freq. range 0.. 100 Hz)</li> </ul>
Resolution measurement of frequency	0.1 Hz
Measuring range (measurement of frequency)	< ±0.01% measuring range (typically < ±0.005%)
Temperature drift (measurement of frequency)	< ±0.002% /°C measuring range
Input resistance	1.2 kΩ ±10%
Input voltage operation (switching level)	0 .. 4 VDC / 5.5 .. 34 VDC (3.6 mA) <sup>(2)</sup> (according to PN-EN61131-2 characteristic)
Maximum input voltage	-0.3 VDC / +36 VDC
Contacts debounce filtering	off / 1 ms / 3 ms
Power supply source for external transducers	24 VDC ±15% / max 50 mA Protected by thermal fuse
Galvanic separation from the other circuits	250 VAC; 1500 VAC for 1 minute
Galvanic separation between channels	None

<sup>(2)</sup>If required, other switching current level at 0.45 mA, 1.55 mA or 2.44 mA can be selected with jumpers located on the module PCB.

#### IN3D – BINARY INPUTS MODULE

Number of inputs	3
Functions	<ul style="list-style-type: none"> <li>• State tracking</li> <li>• Frequency measurement 0.1 .. 12500 Hz</li> <li>• Counting pulses (freq. range 0.. 100 Hz)</li> </ul>
Resolution measurement of frequency	0,1 Hz
Measuring range (measurement of frequency)	< ±0.01% measuring range (typically < ±0.005%)
Temperature drift (measurement of frequency)	< ±0.002% /°C measuring range
Input resistance	1.2 kΩ ±10%
Input voltage operation (switching level)	0 .. 4 VDC / 5.5 .. 34 VDC (3.6 mA) <sup>(2)</sup> (according to PN-EN61131-2 characteristic)

Maximum input voltage	-0.3 VDC / +36 VDC
Contacts debounce filtering	off / 3 ms
Power supply source for external transducers	24 VDC $\pm$ 15% / max 50 mA Protected by thermal fuse
Galvanic separation from the other circuits	250 VAC; 1500 VAC for 1 minute

**Configuration: OC/contact<sup>(1)</sup>**

Open circuit voltage	12 V
Short circuit current	12 mA
On/off threshold	2.7 V / 2.4 V

<sup>(1)</sup>The default setting.

**Configuration: voltage input**

Input resistance	>10 k $\Omega$
On/off threshold	2.7 V / 2.4 V
Open circuit voltage	12 V

**Configuration: Namur**

High impedance state	0.4 .. 1 mA
Low impedance state	2.2 .. 6.5 mA

**2RS485(24V); 2RS485 – RS485 PORTS INPUT MODULE (MODBUS RTU MASTER)**

Number of ports	2
Maximum number of process values read	25 (one or both ports in total)
Signals output on terminal block	A(+), B(-), 2x G (G - signal ground)
Maximum bus load	32 receivers/transmitters
Transmission protocol	Modbus RTU Master
Transmission rate	1.2, 2.4, 4.8, 9.6, 19.2, 38.4, 57.6, 115.2 kbps
Parity control	Even, Odd, None
Frame	1 start bit, 8 data bits, 1 stop bit
Galvanic separation	250 VAC; 1500 VAC for 1 minute
Maximum length of line	1200 m
Internal terminating resistor	V <sub>CC</sub> -A(+)-B(-)-G: 390 $\Omega$ - 220 $\Omega$ - 390 $\Omega$ (activated by DIP-switches)
Maximum differential voltage A(+), B(-)	-9 V .. +14 V
Minimum output signal of transmitter	1.5 V (at R <sub>L</sub> = 54 $\Omega$ )
Minimum sensitivity of receiver	200 mV / R <sub>IN</sub> = 12 k $\Omega$
Minimum impedance of data transmission line	54 $\Omega$
Short-circuit/thermal protection	Yes/Yes
Additional power supply 24 VDC source	
<ul style="list-style-type: none"> <li>• 2RS485(24V) module</li> <li>• 2RS485 module</li> </ul>	<ul style="list-style-type: none"> <li>• 3 four pole terminal block (+ + - -)</li> <li>• 24 VDC <math>\pm</math>15% / max 200 mA</li> <li>• None</li> </ul>

**1HRT – HART (4-20 mA) PORT INPUT MODULE**

Transmission protocol	<ul style="list-style-type: none"> <li>• rev 4, rev 5, rev 6, rev 7</li> <li>• Primary Master or Secondary Master</li> </ul>
Functions	Supported 0, 1, 3, 6, 9 commands: <ul style="list-style-type: none"> <li>• Reading PV, SV, TV, FV and DVC variables</li> <li>• Reading the Long Address (rev 5, rev 6, rev 7)</li> <li>• Changing the Short Address</li> <li>• Reading the unique identifier frame (test)</li> </ul>
Maximum number of devices	15
Maximum number of variables read	25
Multidrop operating mode	Yes, up to 15 devices (multidrop)

Loop power supply	24 VDC (max 60 mA)
Analog reading of the 4-20mA line	No
Galvanic separation from the other circuits	250 VAC; 1500 VAC for 1 minute
Internal resistor	250 $\Omega$ , disabled by default <sup>(3)</sup>

<sup>(3)</sup>The resistor can be switched on/off in the data logger I/O settings menu. The resistor is automatically disconnected in the event of a power outage.

#### OUT6RL – RELAY OUTPUTS MODULE

Number of outputs	6
Sensor type	Solid-state relays (SSR)
Maximum operating voltage / operating current	24 VAC / 0.5 A or 36 VDC / 0.5 A
The maximum voltage allowed	42 VAC or 60 VDC
Maximum peak current	1.5 A for 1 ms
Galvanic separation from the other circuits	250 VAC; 1500 VAC for 1 minute
Galvanic separation between channels	250 VAC; 1500 VAC for 1 minute

#### OUT3 – ANALOGUE OUTPUTS MODULE

Number of outputs (channels)	3
------------------------------	---

##### Specifications for current output

Range (program selected)	4 - 20 mA 0 - 20 mA 0 - 24 mA
Output type	Active current source
Possibility of powering the current loop from an external voltage source	None
Resolution	12 bit / 0.006 mA
Accuracy ( $R_L=350 \Omega$ / $T_a = +25 \text{ }^\circ\text{C}$ )	< $\pm 0.15\%$ ( < $\pm 0.036$ mA) full range of measurement (FSR)
Accuracy ( $R_L=350 \Omega$ / $T_a = -40 \text{ }^\circ\text{C} .. +50 \text{ }^\circ\text{C}$ )	< $\pm 0.3\%$ ( < $\pm 0.072$ mA) full range of measurement (FSR)
Load resistance $R_L$	0 $\Omega$ .. 500 $\Omega$
Maximum output voltage (for $R_L = \infty \Omega$ )	21.5 V

##### Specifications for voltage output

Range (program selected)	0 - 5 VDC 0 - 10 VDC
Output type	DC voltage source
Resolution	12 bit (1.25 mV for 0 - 5 V) (2.5 mV for 0 - 10 V)
Accuracy ( $R_L=1 \text{ k}\Omega/C_L=200 \text{ pF}/T_a=+25 \text{ }^\circ\text{C}$ )	< $\pm 0.1\%$ full range of measurement (FSR) (Typically < $\pm 0.05\%$ FSR)
Accuracy ( $R_L=1 \text{ k}\Omega/C_L=200 \text{ pF}/T_a=-40 \text{ }^\circ\text{C} .. +50 \text{ }^\circ\text{C}$ )	< $\pm 0.3\%$ full range of measurement (FSR)
The minimum load resistance $R_L$	1 k $\Omega$
The maximum load capacitance $C_L$	1 $\mu\text{F}$
Short-circuit protection	Yes

##### Specifications for current and voltage output

Galvanic separation from other circuits	250 VAC; 1500 VAC for 1 minute
Galvanic separation between channels	250 VAC; 1500 VAC for 1 minute

#### PSBATT – MODULE FOR OPERATION WITH A BACK-UP BATTERY<sup>(4)</sup>

Input voltage 24 VDC IN	24 VDC / 2 .. 2.5 A
BATT1, BATT2 (capacity)	NiMH 2x9.6 V / 1000 .. 6000 mAh (Typically 4600 mAh or 2000 mAh)
BATT1, BATT2 temperature sensor	2x NTC 10 k $\Omega$
Charging time	ca. 12 h (full charging)

<sup>(4)</sup>In the device, it is possible to instal only 1 PSBATT module. From April 1, 2020, the PSBATT module is manufactured only in version 1.2. Version 1.2 of the module is not backward compatible. The Datasheet contains information about the module's technical data in version 1.2. Technical details about the module in version 1.0 and in version 1.1 are available from the Manufacturer. Use only dedicated power supply.

**TABLE OF RTD SENSORS**

Sensor type	Range	Accuracy
Pt100, Pt200, Pt500, Pt1000 (EN 60751+A2:1995)	-200 °C .. +850 °C -328 °F .. +1562 °F	$\pm 0.5$ °C (typically $\pm 0.3$ °C) $\pm 0.9$ °F (typically $\pm 0.5$ °F)
Ni100, Ni120, Ni1000 (DIN43760 /08-1985)	-60 °C .. +250 °C -76 °F .. +482 °F	$\pm 0.5$ °C (typically $\pm 0.3$ °C) $\pm 0.9$ °F (typically $\pm 0.5$ °F)
Cu50, Cu53, Cu100 (GOST6651-2009)	-180 °C .. +200 °C -292 °F .. +392 °F	$\pm 0.5$ °C (typically $\pm 0.3$ °C) $\pm 0.9$ °F (typically $\pm 0.5$ °F)
KTY81 (NXP Rev05-25.04.2008)	-55 °C .. +150 °C -67 °F .. +302 °F	$\pm 0.5$ °C $\pm 0.9$ °F
KTY83 (NXP Rev06-4.04.2008)	-55 °C .. +175 °C -67 °F .. +347 °F	$\pm 0.5$ °C $\pm 0.9$ °F
KTY84 (NXP Rev06-8.05.2008)	-40 °C .. +300 °C -40 °F .. +572 °F	$\pm 0.8$ °C $\pm 1.5$ °F
Linear resistance	0 .. 4700 $\Omega$ (or sub-range)	$\pm 0.5$ $\Omega$ (typically $\pm 0.3$ $\Omega$ )

**TABLE OF THERMOCOUPLES (TC)**

Sensor type	Range	Accuracy
J (Fe-CuNi) (EN60584-1:1995)	-210 °C .. +1200 °C (compensation range -100 °C .. +300 °C) -346 °F .. +2192 °F (compensation range -148 °F .. +572 °F)	$\pm 1.0$ °C (typically $\pm 0.5$ °C) $\pm 1.8$ °F (typically $\pm 0.9$ °F) (without compensation)
K (NiCr-NiAl) (EN60584-1:1995)	-270 °C .. + 1372 °C (compensation range -100 °C .. +300 °C) -454 °F .. +2501.6 °F (compensation range -148 °F .. +572 °F)	$\pm 1.0$ °C (typically $\pm 0.5$ °C) $\pm 1.8$ °F (typically $\pm 0.9$ °F) (without compensation)
N (NiCrSi-NiSi) (EN60584-1:1995)	-270 °C .. +1300 °C (compensation range -100 °C .. +300 °C) -454 °F .. +2372 °F (compensation range -148 °F .. +572 °F)	$\pm 2.0$ °C (typically $\pm 1.0$ °C) $\pm 3.6$ °F (typically $\pm 1.8$ °F) (without compensation)
R (PtRh 13-Pt) (EN60584-1:1995)	-50 °C .. +1768 °C (compensation range -50 °C .. +300 °C) -58 °F .. +3214.4 °F (compensation range -58 °F .. +572 °F)	$\pm 2.0$ °C (typically $\pm 1.0$ °C) $\pm 3.6$ °F (typically $\pm 1.8$ °F) (without compensation)
S (PtRh 10-Pt) (EN60584-1:1995)	-50 °C .. +1768 °C (compensation range -50 °C .. +300 °C) -58 °F .. +3214.4 °F (compensation range -58 °F .. +572 °F)	$\pm 2.0$ °C (typically $\pm 1.0$ °C) $\pm 3.6$ °F (typically $\pm 1.8$ °F) (without compensation)
T (Cu-CuNi) (EN60584-1:1995)	-200 °C .. +400 °C (compensation range -50 °C .. +300 °C) -328 °F .. +752 °F (compensation range -58 °F .. +572 °F)	$\pm 1.0$ °C (typically $\pm 0.5$ °C) $\pm 1.8$ °F (typically $\pm 0.9$ °F) (without compensation)
E (NiCr-CuNi)	-270 °C .. +1000 °C	

<b>(EN60584-1:1995)</b>	(compensation range -50 °C .. +300 °C) -454 °F .. +1832 °F (compensation range -58 °F .. +572 °F) +250 °C .. +1820 °C	±1.0 °C (typically ±0.5 °C) ±1.8 °F (typically ±0.9 °F) (without compensation)
<b>B (PtRh30-PtRh6) (EN60584-1:1995)</b>	(without compensation) +482 °F .. +3308 °F (without compensation)	±2.0 °C (typically ±1.0 °C) ±3.6 °F (typically ±1.8 °F) (without compensation)
<b>L (Fe-CuNi) (DIN43710)</b>	(compensation range -50 °C .. +300 °C) -328 °F .. +1652 °F (compensation range -58 °F .. +572 °F) -200 °C .. +900 °C	±1.0 °C (typically ±0.5 °C) ±1.8 °F (typically ±0.9 °F) (without compensation)
<b>U (Cu-CuNi) (DIN43710)</b>	(compensation range -50 °C .. +300 °C) -328 °F .. +1112 °F (compensation range -58 °F .. +572 °F) -200 °C .. +600 °C	±1.0 °C (typically ±0.5 °C) ±1.8 °F (typically ±0.9 °F) (without compensation)
<b>Line voltage</b>	-140 .. +140 mV (or sub-range)	<0.2% full range

Data sheet version: 230905 EN / Device version: 1.0